

COATS

950/1025/1050/1055

Solid State

WHEEL BALANCER

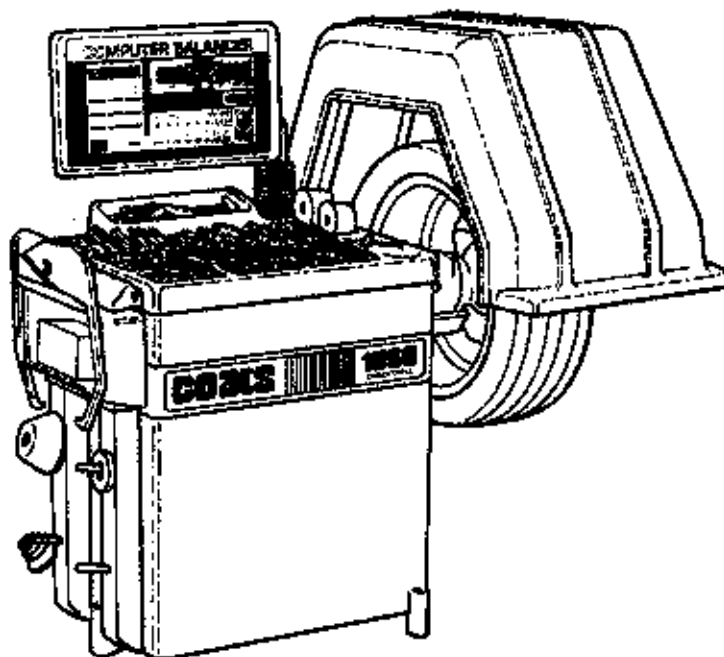

Installation Instructions
Operating Instructions
Safety Instructions
Maintenance Instructions

READ these instructions before placing unit in service KEEP these and other materials delivered with the unit in a binder near the machine for ease of reference by supervisors and operators.

HENNESSY INDUSTRIES, INC.

1601 J. P. Hennessy Drive, LaVerne, TN USA 37086-3565 615/641-7533 800/688-6359

HENNESSY INDUSTRIES, INC., Manufacturer of AMVCC®, COATS® and BADA® Automotive Service Equipment and Tools.

Manual Part No. 811868-09

Revised 03/08



Table of Contents

Operator Protective Equipment	iv	Selecting Balancing Options	
Owner's Responsibility	v	Hood Start	12
Definitions of Hazard Levels	v	Round Off	12
Important Safety Instructions	vi	Ounce/Gram	12
Before You Begin		Operator A/B	12
Receiving	1	Clear	12
Electrical Requirements	1	Blank Rim	12
Specifications	1	Reading the Displays	
Standard Accessories	1	Weight Displays	12
Optional Accessories	1	Weight Position LEDs	12
Features	2	Display Messages	12
Installation and Setup		Balancing a Wheel	
Floor and Space Requirements	2	Procedure	13
Unpack and Setup the Unit	2	Changing Wheel Information During Balancing ..	13
Connecting Power	5	Changing Balancing Modes During Balancing ..	13
Initial Testing	5	Checking the Balance	13
Balancer Operation Overview		After Balancing Vibration Checklist	13
Determining the Planes	6	Match Mount	
Balancing a Wheel	6	Description	14
Control Panel	7	Instructions	14
Mounting Wheels		Maintenance and Calibration	
Back Cone Mounting	8	Preventative Maintenance	16
Front Cone Mounting	8	Calibration	16
Alternate Mounting	9	Distance Gauge Calibration	17
Optional Combi-Adapter Mounting	9		
Wheel Data Entry		1025 Watch for this symbol. It indicates that the	
Wheel Offset - A	10	1050 instruction or option described is for	
Wheel Width - W	10	1055 Models 1025, 1050, and 1055 only.	
Wheel Diameter - D	10		
Selecting Balancing Mode			
Dynamic Balancing	11		
RV Balancing	11		
Alloy 1	11		
Alloy 2	11		
Alloy 3	11		
Alloy 4	11		
Static	11		
Match Mount	11		

Operator Protective Equipment

Personal protective equipment helps make tire servicing safer. However, equipment does not take the place of safe operating practices. Always wear durable work clothing during tire service activity. Loose fitting clothing should be avoided. Tight fitting leather gloves are recommended to protect operator's hands when handling worn tires and wheels. Sturdy leather work shoes with steel toes and oil resistant soles should be used by tire service personnel to help prevent injury in typical shop activities. Eye protection is essential during tire service activity. Safety glasses with side shields, goggles, or face shields are acceptable. Back belts provide support during lifting activities and are also helpful in providing operator protection. Consideration should also be given to the use of hearing protection if tire service activity is performed in an enclosed area, or if noise levels are high.



Failure to follow danger, warning, and caution instructions may lead to serious personal injury or death to operator or bystander or damage to property. Do not operate this machine until you read and understand all the dangers, warnings and cautions in this manual. For additional copies of either, or further information, contact:

Hennessy Industries, Inc.

1601 J.P. Hennessy Drive
LaVergne, TN 37086-3565
(615) 641-7533 or (800) 688-6359



Do it Now

Make sure the instruction and warning decal is clean and clearly visible to operator.

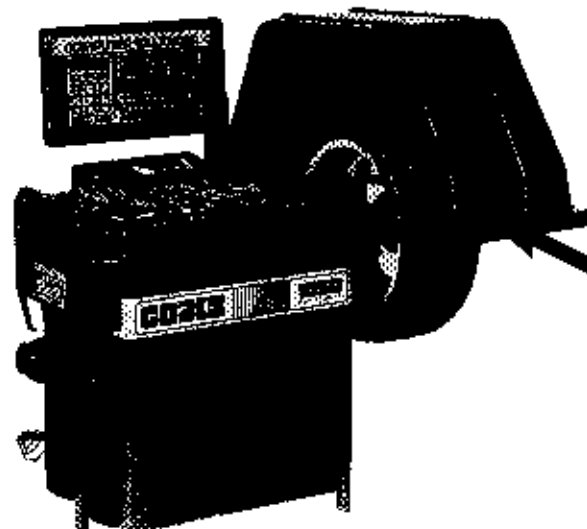

NOTICE

Read entire manual before assembling, installing, operating, or servicing this equipment.

Owner's Responsibility

To maintain machine and user safety, the responsibility of the owner is to read and follow these instructions:

- Follow all installation instructions.
- Make sure installation conforms to all applicable Local, State, and Federal Codes, Rules, and Regulations; such as State and Federal OSHA Regulations and Electrical Codes.
- Carefully check the unit for correct initial function.
- Read and follow the safety instructions. Keep them readily available for machine operators.
- Make certain all operators are properly trained, know how to safely and correctly operate the unit, and are properly supervised.
- Allow unit operation only with all parts in place and operating safely.
- Carefully inspect the unit on a regular basis and perform all maintenance as required.
- Service and maintain the unit only with authorized or approved replacement parts.
- Keep all instructions permanently with the unit and all decals/labels/notices on the unit clean and visible.
- Do not override safety features.

Definitions of Hazard Levels

Identify the hazard levels used in this manual with the following definitions and signal words:

DANGER

Watch for this symbol:



It Means: Immediate hazards, which will result in severe personal injury or death.

WARNING

Watch for this symbol:



It Means: Hazards or unsafe practices, which could result in severe personal injury or death.

CAUTION

Watch for this symbol:



It Means: Hazards or unsafe practices, which may result in minor personal injury or product or property damage.



Watch for this symbol! It means BE ALERT! Your safety, or the safety of others, is involved!

IMPORTANT SAFETY INSTRUCTIONS

READ ALL INSTRUCTIONS

1. Eye and face protection recommendations:
"Protective eye and face equipment is required to be used where there is a reasonable probability of injury that can be prevented by the use of such equipment." O.S.H.A. 1910.133(a) Protective goggles, safety glasses, or a face shield must be provided by the owner and worn by the operator of the equipment. Care should be taken to see that all eye and face safety precautions are followed by the operator. ALWAYS WEAR SAFETY GLASSES. Everyday glasses only have impact resistant lenses, they are not safety glasses.
2. Do not disable hood safety interlock system, or in any way shortcut safety controls and operations.
3. Be sure that wheels are mounted properly, the hub nut engages the arbor for not less than four (4) turns, and the hub nut is firmly tightened before spinning the wheel.
4. Read and understand this manual before operating. Abuse and misuse will shorten the functional life.
5. Be sure the balancer is properly connected to the power supply and electrically grounded.
6. Do not operate equipment with a damaged cord or if the equipment has been dropped or damaged – until it has been examined by a qualified serviceman.
7. Do not let cord hang over edge of table, bench, or counter or come in contact with hot manifolds or moving fan blades.
8. If an extension cord is necessary, a cord with a current rating equal to or more than that of the equipment should be used. Cords rated for less current than the equipment may overheat. Care should be taken to arrange the cord so that it will not be tripped over or pulled.
9. Keep guards and safety features in place and in working order.
10. Wear proper clothing. Safety toe, non-slip footwear and protective hair covering to contain hair is recommended. Do not wear jewelry, loose clothing, neckties, or gloves when operating the balancer.
11. Keep work area clean and well lighted. Cluttered and/or dark areas invite accidents.
12. Avoid dangerous environments. Do not use power tools or electrical equipment in damp or wet locations, or expose them to rain.
13. Avoid unintentional starting. Be sure the balancer is turned off before servicing.
14. Disconnect the balancer before servicing.
15. Use only manufacturer's recommended accessories. Improper accessories may result in personal injury or property damage.
16. Repair or replace any part that is damaged or worn and that may cause unsafe balancer operation. Do not operate damaged equipment until it has been examined by a qualified service technician.
17. Never overload or stand on the balancer.
18. Do not allow untrained persons to operate machinery.
19. To reduce the risk of fire, do not operate equipment in the vicinity of open containers or flammable liquids (gasoline).
20. Adequate ventilation should be provided when working on operating internal combustion engines.
21. Keep hair, loose clothing, fingers, and all parts of body away from moving parts.
22. Use equipment only as described in this manual.
23. Use only manufacturer's recommended attachments.

SAVE THESE INSTRUCTIONS

Before You Begin

Receiving

The shipment should be thoroughly inspected as soon as it is received. The signed bill of lading is acknowledgement, by the carrier, of receipt in good condition of the shipment covered by our invoice.

If any of the goods called for on this bill of lading are shorted or damaged, do not accept them until the carrier makes a notation of the shorted or damaged goods on the freight bill. Do this for your own protection.

NOTIFY THE CARRIER AT ONCE if any hidden loss or damage is discovered after receipt and request him to make an inspection. If the carrier will not do so, prepare an affidavit to the effect that you have so notified the carrier (on a certain date) and that he has failed to comply with your request.

IT IS DIFFICULT TO COLLECT FOR LOSS OR DAMAGE AFTER YOU HAVE GIVEN THE CARRIER A CLEAR RECEIPT.

File your claim with the carrier promptly. Support your claim with copies of the bill of lading, freight bill, invoice, and photographs, if possible.

Although Coats responsibility ceases upon delivery of the shipment to the carrier, we will gladly assist in tracing lost shipments. Our willingness to assist in every possible manner does not make COATS responsible for collection of claims, or replacement of lost or damaged materials.

Electrical Requirements

The balancer requires a 220 VAC, 60Hz, three-phase power supply with 20 amp fuse or circuit breaker, or a 220 VAC, 60 Hz, single-phase power supply with 20 amp fuse or circuit breaker.

The three-phase balancer is equipped with an approved cord and a 4-prong grounding plug to fit a Hubbell 2420 or Bryant 71520 grounding receptacle (not included).

The single-phase balancer is equipped with an approved cord and a 3-prong grounding plug to fit a Hubbell 2320 or Bryant grounding receptacle (not included).

The receptacles should be installed by a qualified electrician in accordance with state and local codes.

Specifications

- Cycle time5 seconds (avg.)
- Outside Tire Diameter40 inches max.
- Max Tire Weight150 pounds (68 Kg)
- Wheel Diameter Range10 to 24 inches
- Wheel Width Range2.7 to 18.6 inches
- Balancing Increments0.25 or 0.01 ounce
- Resolution (Round Off Mode) . . .0.01 ounce, 1.4°
- Motor - Modified torque with 900 RPM/1.5 HP rating, forced air cooling, large housing for heat dissipation, and heavy duty insulation for high temperature applications.
- Shipping Weight550 pounds (249.79 Kg)

Standard Accessories

- Graduated Cone Assortment (hardened, 3 piece)
- Large Adapter (truck cone)
- Cone Spring
- Hub Nut
- No-Mar Ring
- Rim Width Calipers
- Wheel Weight Pliers

Optional Accessories

- Combi-Adapter for Bolt Hole Mounting
- Extra Large Truck Cone Kit
- 3, 4, and 5 Lug Universal Adapters
- Escort/Lynx Adapter
- Speed Lock Kit
- Side and Rear Storage Trays
- Additional Accessory Pegs (for rear of balancer)
- Viper Wheel Kit
- Large Truck Cone and Cup Adapter Kit Assembly and Setup

Features

- Exclusive Direct Drive System - No Belts or Pulleys
- Single-Spin Balancing
- Vertical Wheel Mounting
- Hood Safety Interlock System
- Extended Mounting Flange for Deeper Wheels
- Removable Center Shaft for Closed Center Wheels and Combi-Adapter Mounting
- Dynamic, Static, RV, Match Mount, and four Alloy Balancing Modes
- Adjustable Control Panel
 - Scratch and Solvent Resistant
 - Large, Bright Digital Displays
 - Easy-to-Read Position Indicators
 - Large Keypad for Data Entry
 - Easily Repositioned for Best Visibility
 - Electronics Isolated from Motor Heat
 - Automatic Memory and Program Check
- Operator A/B
- Automatic Data Entry for Offset and Diameter
- Self-Calibrating
- Wheel Weight Bins - Standard, Custom, and Tape-A-Weight
- Four Storage Pegs for Accessories
- Convenient Cone and Hub Nut Storage in Top Tray
- "No Bolt-Down" Installation
- Side Storage Tray for Extra Wheel Weights (optional on 950)
- Solid State Motor Control

Installation and Setup

A factory trained COATS® Service Technician must perform the install, setup, and initial test procedures on your 950, 1025, 1050, or 1055 balancer. Do not attempt to install and setup the unit yourself. Accurate and reliable operation of your unit depends on proper installation. Please contact COATS® directly at 1-800-688-9240 for the Certified Service Partner nearest you.

Floor and Space Requirements

The balancer must be located on a flat floor of solid construction, preferably concrete. The balancer must sit solidly on its 3 feet. If the balancer is not level, does not sit solidly on its 3 feet, or is placed on an unstable floor, the balancer will not function properly and will produce inaccurate balance readings.

The balancer is not designed to be bolted down, nor will it function properly if left on the pallet.

Select a location for the balancer that provides a level, solid floor, and adequate clearance around and above the balancer (Figure 1). Make sure the location selected has enough room above and behind the unit so the hood can be raised completely. The location must also provide working room for mounting and removing wheels.

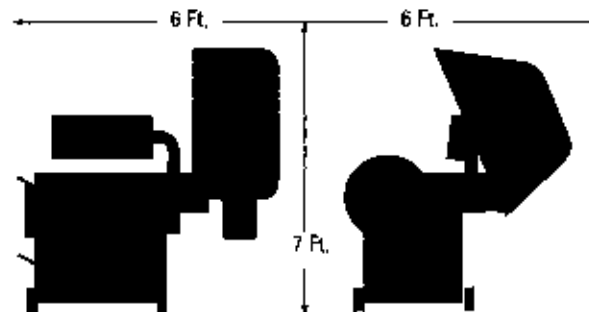

Figure 1 - Space Requirements

Unpack and Setup the Unit

1. Remove the carton from the pallet.
2. Remove the shipping bolts in the three support feet.
3. Cut the strap holding the hood in shipping position.



Do not use the control pod, control pod arm, faceplate, hood or stub shaft to lift the balancer.



Use help to remove the balancer from the pallet. The unit is heavy and the weight is not evenly distributed. Dropping the unit may cause personal injury or equipment damage.

4. Lift the balancer off the pallet.
5. Open the accessory box and remove the hood assembly hardware and hood spring.
6. Install the hood stop if not already pre-assembled.

CAUTION

Improper hood assembly installation may result in mechanical switch damage causing the balancer not to operate. Use help and carefully follow the hood assembly installation instructions as described below.

7. Locate the hood assembly.
8. Slide one flanged bearing onto the stationary hood bar; flange to cam (figure 2).
9. Next, install the hood assembly to the hood bracket.
10. Slide the other flanged bearing into position followed by the washer, retainer and cap plug (figure 2).
11. Raise the hood all the way and verify that the hood stop bracket on the side of the hood contacts the rubber hood stop solidly. Lower the hood and verify that the other end of the hood stop bracket contacts the rubber hood stop solidly.

12. Raise the hood and hold it up.

CAUTION

Use help to hold the hood while attaching the hood spring. Attaching the spring without holding the hood in place may cause it to snap open suddenly, resulting in personal injury.

13. Hook the other hook end of the hood spring under the balancer.
14. Hook the other end of the spring over the pin in the rear of the hood stop bracket. Make sure the spring fits into the groove in the pin.

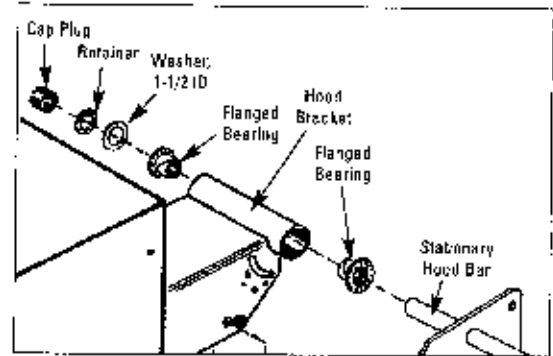

Figure 2 - Hood Assembly Installation

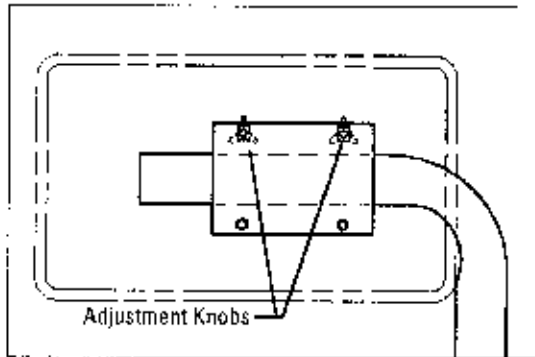

Figure 6 - Control Pod Adjustment Knobs

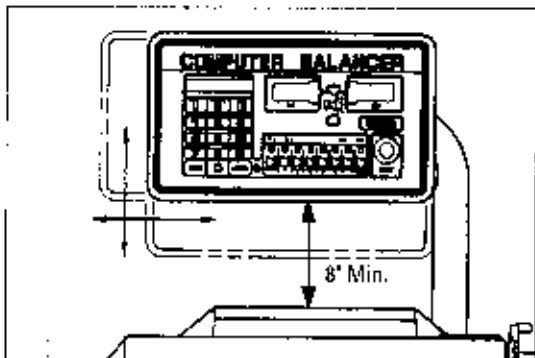

Figure 7 - Control Pod Height

16. Loosen the four 5/16" nuts and raise the control pod support arm. Raise it high enough to allow room for the pod to rotate into position and for the Match Mount instructions to lower below the pod.

18. Lightly tighten the control pod support arm retainer nuts on the side of the support bracket. Arm will be adjusted and tightened later.

17. Loosen the two adjustment knobs on the back of the control pod (Figure 6).

18. Rotate the pod into operating position, and retighten the knobs.

19. Loosen the nuts on the support arm retainers. Raise or lower the control pod into the desired position, and tighten the retainer nuts securely. The bottom edge of the pod should be at least 8 inches above the top of the balancer (Figure 7).

20. Lower the Match Mount instructions attached to the underside of the control pod. If there is not enough room between the pod and the balancer weight tray to fully lower the instruction card, the pod should be raised.

21. Position the balancer in its final operating location. Lightly tighten the four 5/16" nuts

22. Install the wheel caliper hook on the outside of the hood (away from the balancer). Remove the 1/4" screw (towards the rear of the hood), position the caliper hook over the hole, and reinstall the screw.

23. Install the side pocket (1050 standard, 950 optional) and accessory peg brackets/covers (950 and 1050 standard). Mounting holes are provided on the side and rear of the balancer to allow the pockets and peg brackets to be installed according to user requirements. Mount up to three side pockets or two peg brackets on the side or the rear. Contact your Hennessy Representative to order additional pockets or brackets.

Connect to Power

Your factory trained COATS® Service Technician should do the final check to verify the power installation before connecting the balancer to a power supply. Failure due to improper power connection will void the warranty.

Connect the balancer to an appropriate electrical receptacle. Refer to Figure 8 and 9, as well as Electrical Requirements on page 1.

Note: If pedestrian or equipment traffic might damage the standard power cord, power outlets must be enclosed in a raceway on the floor or in an overhead drop.

Note: Electric outlets must be solidly connected. There should be less than 1 Ω electrical resistance between the ground pin and earth ground. The installer or electrical inspector must verify the outlet installation before connecting the balancer. Failure due to improper power connection will void the warranty.

Note: The green wire in the cord is the grounding wire. Never connect the green wire to a live terminal.

Initial Testing

This should be performed by your factory trained COATS® Service Technician.

1. If the circuit breaker for the balancer outlet is off, turn it on now. Turn the balancer ON/OFF switch to ON.

Remember: To maintain the proper operating temperature for the balancer, the unit should be left on all day.

2. The displays will show zeros when the unit is first turned on. Press any key to continue.

3. Verify that the fan is running by placing your hand between the arbor faceplate and the motor housing. You should feel air coming out from around the motor housing. Do not operate the balancer if airflow is not present when the balancer is on.

4. Lower the hood and press START. The arbor faceplate should spin in the direction indicated by the label at the outer edge of the motor cover (clockwise when viewed straight on).

If the faceplate spins counterclockwise, turn the balancer off, turn the circuit breaker off, and disconnect the balancer plug. Swap two of the hot wires connected to the receptacle. Reconnect the balancer to the receptacle, turn the circuit breaker on, then turn the balancer on. Lower the hood and press START and recheck the direction of the spin. The faceplate should now be spinning in a clockwise direction.

Note: Single-phase balancers will also spin in a clockwise direction.

Note: Disregard a short spin cycle with HUB displayed on the control panel during this initial testing.

5. Raise the hood during a spin cycle to verify that the hood interlock system is functioning properly.

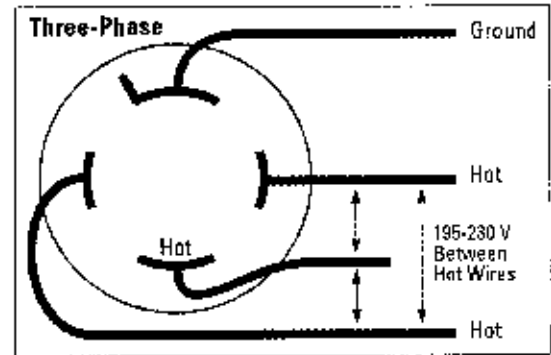

Figure 8 - Three-Phase Wiring Diagram

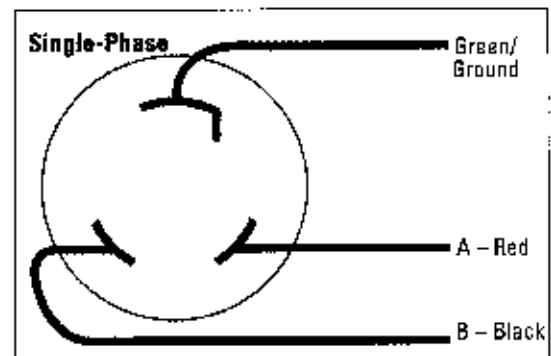

Figure 9 - Single-Phase Wiring Diagram

Balancer Operation Overview

This machine is a two-plane, microprocessor-based computer balancer. Any imbalance in a wheel, either static or dynamic, is resolved into two correction planes (usually the inner and outer flanges of the wheel) where corrective weights can be applied. Pressing MODE and selecting the DYNAMIC, ALLOY, STATIC, or RV mode can change the location of these planes.

Determining the Planes

1025
1050
1055 When the distance gauge is pulled out and held against the wheel flange, the computer automatically registers the distance (referred to in these instructions as the A Offset measurement). The computer will "beep" to indicate it has stored the measured distance. This distance measurement (the Offset) tells the computer the location of the inner plane of the wheel for Dynamic balancing.

1025
1050
1055 While the distance gauge is held in contact with the wheel flange, the computer also calculates the wheel diameter (D measurement). The diameter measurement is automatically entered (along with the offset measurement) when the computer BEEPS. The diameter measurement tells the computer how far from the center of the hub the weights will be applied.

The offset and diameter measurement principles are the same for the 950, however the operator must enter the measurements, instructions on page 8.

When the wheel width is entered into the computer, it is automatically added to the offset measurement to determine the outer plane of the wheel. The wheel width is entered manually by the operator as the W measurement.

Balancing a Wheel

When a wheel is spun, the balancer detects any imbalance present. The computer calculates the weight needed to correct the imbalance and the location for weight application. The weight required to correct the imbalance is displayed on the control panel, and the weight positioning lights assist the operator in positioning the weight application location at top-dead-center. Weight displays and positioning lights are provided for both inner and outer planes of the wheel.

The stop-on-top feature of the 1050 is designed to stop the spinning wheel with the outer weight application location near top-dead-center, if no imbalance is detected.

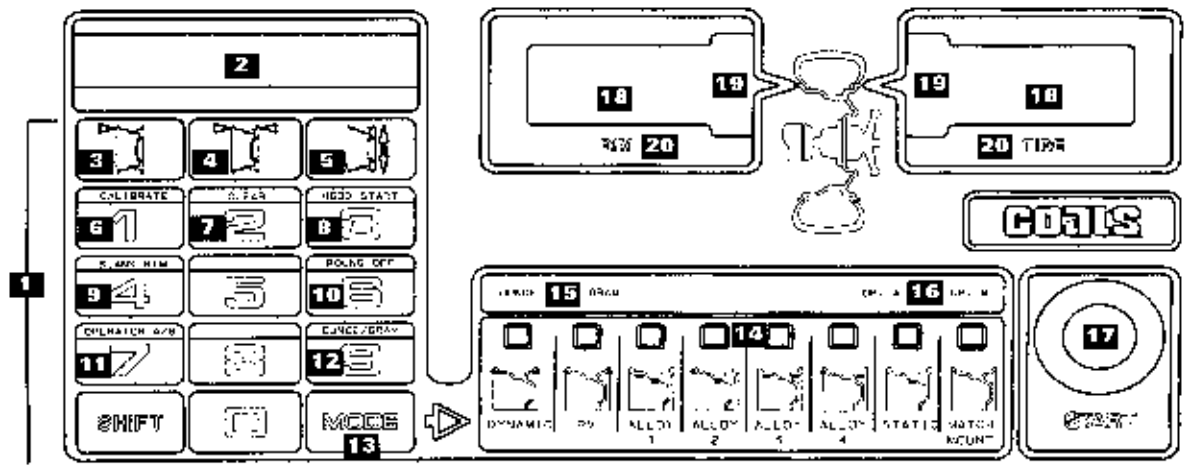

Control Panel

1 Keypad - User enters information and selects function using these keys.

2 Wheel Measurement Display - Displays A, W, and D values.

3 Wheel Offset (A) - The distance between the inner rim flange and the edge of the balancer. Refer to Data Entry beginning on page 9 for detailed instructions.

4 Wheel Width (W) - The width of the rim between the inner and outer rim flanges. Refer to Data Entry beginning on page 9 for detailed instructions.

5 Wheel Diameter (D) - The diameter of the wheel at the weight location. Refer to Data Entry beginning on page 9 for detailed instructions.

6 Calibrate - Places the balancer in the Calibrate Mode. Press and hold the SHIFT key, and press 1.

1025 7 Clear - Clears all entered measurements
1050 and user preferences for the operator memory
1055 in use (Operator A/B). The other operator memory remains intact. Press and hold the SHIFT key, and press 2.

8 Hood Start - Sets the balancer to automatically start the spin cycle when the hood is lowered. Press and hold the SHIFT key, and press 3. Repeat the key sequence to turn the option off.

1025 9 Blank Rim - Turns the wheel diameter
1050 measurement display off (balancer continues
1055 to utilize this measurement). Press and hold the SHIFT key, and press 4. Repeat the key sequence to turn the display back on.

10 Round Off - Toggles the balancer between the high accuracy mode (0.01-ounce increments) and the normal mode (0.25-ounce increments). Press and hold the SHIFT key, and press 6.

11 Operator A/B - Toggles the balancer
1050 between two operator memories. Allows the balancer to be used by a second operator without clearing the measurements or data stored by the first operator. All measurements and preferences entered into one operator memory are retained when the other operator memory is selected. Press and hold the SHIFT key, and press 7.

12 Ounce/Gram - Toggles the balancer between ounces or grams. Press and hold the SHIFT key, and press 9.

13 Mode - Selects the desired balancing mode.

14 Balancing Modes - Press the MODE key to select from the 8 available modes. The LED above the mode will illuminate to indicate the mode is selected.

15 Weight Unit LEDs - Indicates that weight readings are shown in ounces or grams (see 12).

1025 16 Operator LEDs - Indicates operator mem-
1050 ory in use (see 11).
1055

17 Start Button - Press to start a spin cycle.

18 Weight Displays - Indicate the weight amount to be attached to the wheel.

19 Weight Position LEDs - Center LEDs flash when correct weight position is at top-dead-center.

20 Rim/Tire Reading Indicators - When lit, the readings in the displays represent the weight values for the rim and tire individually. Used only with Match-Mount.

Mounting Wheels

Select the most appropriate mounting method for the wheel you are balancing. Using the proper method ensures secure mounting and safe balancer operation, and prevents damage to the wheel.

On most wheels, the inner side of the wheel hub usually has the most uniform surface for wheel balancing. Always center the wheel by the most uniformly shaped side of the hub to achieve the most accurate balance.

Regardless of mounting type, always make sure that the wheel is forced firmly against the arbor faceplate and that the hub nut engages the threaded arbor for at least four complete turns. To assist in centering the wheel properly, rotate the wheel on the arbor while tightening the hub nut.

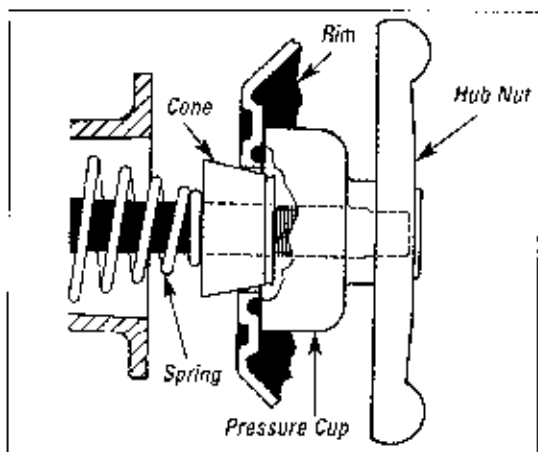

Figure 10 - Back Cone Mounting

Back Cone Mounting

Most original equipment and steel wheels can be mounted properly using this method. The wheel is centered on a cone from the inner side of the hub.

1. Place the cone spring on the arbor with the large end towards the balancer.
2. Select the cone that best fits the center hole in the wheel. Slide the cone onto the arbor with the large end towards the spring.
3. Lift the wheel onto the arbor and center it on the cone.
4. Attach the pressure cup to the hub nut and spin the assembly onto the arbor. Tighten securely.

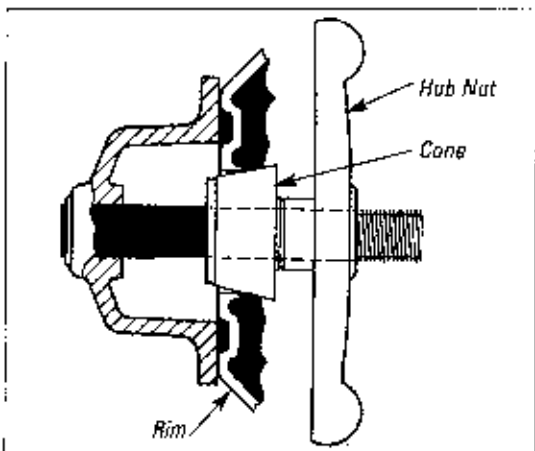

Figure 11 - Front Cone Mounting

Front Cone Mounting

A wheel should be centered by the outer side of the hub only when the inner surface will not provide an accurate surface to center on.

1. Select the cone that best fits the center hole in the wheel.
2. Lift the wheel onto the arbor and slide it back against the arbor faceplate.
3. Slide the cone onto the arbor and into the center of the wheel. Then lift the tire to seat the cone in the center hole.
4. Spin the hub nut (without the pressure cup) onto the arbor. Tighten it securely against the cone.

Alternate Mounting

If the wheel has a protruding outer hub which will not permit the use of the pressure cup, or the cup will not permit the hub nut to engage at least four turns of the arbor, this alternate method should be used.

1. Place the cone spring on the arbor with the large end towards the balancer.
2. Select the cone that best fits the center hole in the wheel. Slide the cone onto the arbor with the large end towards the spring.
3. Lift the wheel onto the arbor and center it on the cone.
4. Use the small nylon spacer (no-mar ring) or a centering cone to press against the outer wheel hub.
5. Spin the hub nut (without the pressure cup) onto the arbor. Tighten securely.

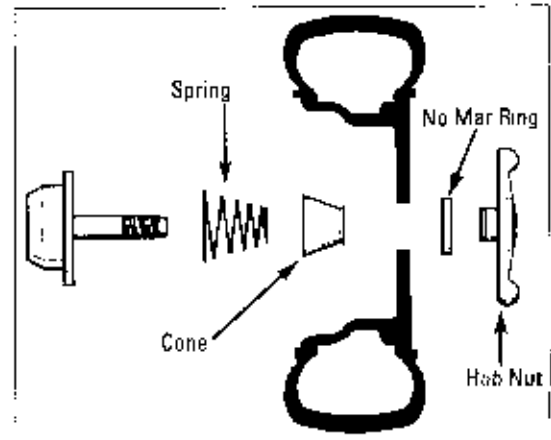

Figure 12 - Alternate Mounting

Optional Combi-Adapter Mounting

Use this method for wheels without a center hole, for a center hole that is out of round, or center holes that do not fit the mounting cones. This adapter allows the mounting of 3, 4, 5, 6, 8, or 10 lug wheels by installing 3, 4, or 5 swivel plates on the adapter plate.

1. Assemble the adapter according to the instructions provided.
2. Attach the adapter to the wheel. The lug nuts must properly seat in the lug holes and engage at least four full threads for a secure mounting. Use the wrench provided with the adapter, and never use air tools or impact wrenches.
3. Remove the threaded arbor (if necessary for wheels without a center hole).
4. Lift the wheel onto the balancer and align the adapter base plate studs with the holes in the arbor faceplate. Secure the adapter/wheel to the faceplate using the thumbnuts. To properly center the wheel, tighten the thumbnuts in an alternating pattern while rotating the wheel.

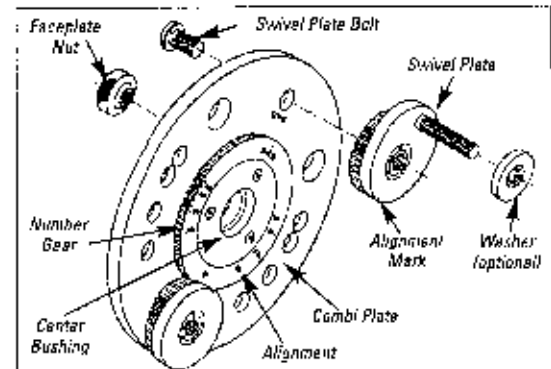

Figure 13 - Optional Combi-Adapter

Wheel Data Entry

Before a wheel can be balanced, the size of the wheel must be entered into the computer. The user enters the data either automatically or manually.

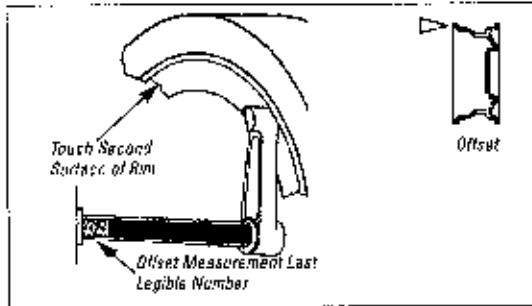

Figure 14 - Measuring Wheel Offset with Distance Gauge

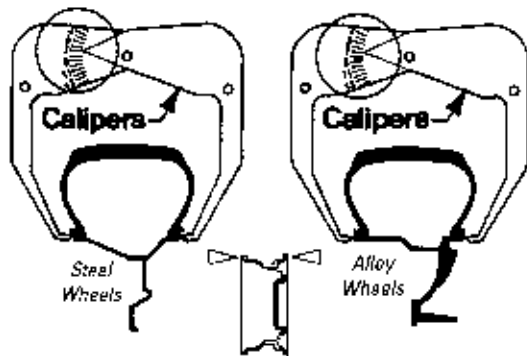

Figure 15 - Measuring Wheel Width with the Calipers

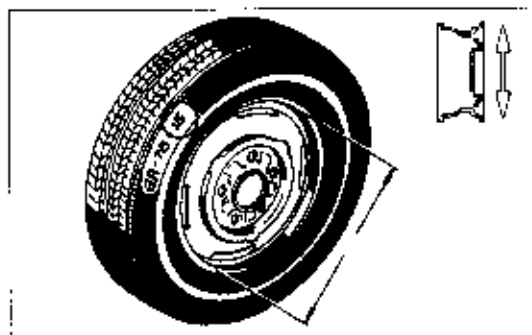

Figure 16 - Wheel Diameter

Wheel Offset - A

This is the distance between the edge of the balancer and the inner edge of the wheel.

1025 **1. For Automatic Entry** - Pull the distance gauge out from the side of the balancer. Rotate it until the handle end of the gauge contacts the inner wheel flange. Hold the gauge against the wheel until the balancer BEEPS to indicate it has accepted the measurement, which is displayed above the wheel offset key.

Note: When entering A data automatically, D (wheel diameter) is also determined and entered.

2. For Manual Entry - Press the wheel offset key. Pull the distance gauge out in the same manner as outlined for automatic entry. Hold the gauge against the wheel flange and read the measurement on the gauge. Use the keypad to enter the measurement. For example, if the last large number (inch indicator) visible is 6, and the last small number (fraction of an inch) visible is 4, press 6 then 4 on the keypad to enter 6.4 inches.

Wheel Width - W

This is the width of the wheel measured with the calipers at the rim flanges.

1. Press the wheel width key. If offset and diameter are entered automatically on the 1050, the balancer will activate the width key after the acceptance BEEP.

2. Open the calipers wide enough to reach around the tire. Close the calipers so both tips contact the rim flanges. Read the rim width on the calipers.

3. Enter the measurement using the keypad. It is now shown in the display above the wheel width key.

Wheel Diameter - D

This is the diameter of the wheel at the weight location.

1025 Automatic diameter entry reads to 3 decimal places internally and rounds to 0.10-inch values. It is not necessary to convert metric diameter measurements to inches. For manual entry, enter 15.4 for 390 metric wheels, and 15.7 for 400 wheels. The displayed value represents the diameter for weight placement and is not necessarily representative of the actual wheel diameter. A 14-inch wheel may display 13.6 to 14.3 depending on rim lip configuration and the offset used by the computer.

1025 **1. For Automatic Entry** - If the wheel offset measurement was entered automatically, the 1050 has also calculated and entered the wheel diameter and displayed it above the wheel diameter key.

2. For Manual Entry - Press the wheel diameter key. Locate the tire size on the tire sidewall and determine the wheel diameter. Use the keypad to enter the measurement. It is now displayed above the wheel diameter key. The computer calculates the actual weight placement diameter.

Selecting Balancing Mode

Eight separate balancing modes are available on the 1050S. Select the balancing mode based on wheel type and customer request. Press the mode key to select the desired balance type. The LED will illuminate to indicate your selection. In the alloy and static modes, the balancer will automatically adjust the wheel diameter to compensate for the actual location of the weight(s).

Dynamic Balancing

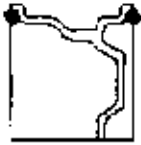

The most common mode used for passenger cars and light trucks. Selecting this mode tells the balancer that standard clip weights will be used on the inner and outer rim flanges.

Alloy 3



Use this mode when clip weights cannot be used, and hidden adhesive weights are not requested. Tells the balancer that you are using adhesive weights on the horizontal planes on both the inner and outer sides of the rim.

RV Balancing

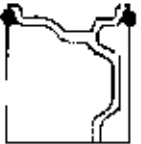

Use this mode to balance larger wheels that do not require balancing at 0.5 ounce or below.

Alloy 4



Use this mode when a clip weight cannot be used on the outer rim flange, and hidden adhesive weights are not requested. Attach the adhesive weight to the horizontal plane on the outer edge of the wheel.

Alloy 1



Use this mode when clip weights on the rim flanges is not possible, or the customer requests hidden weights. Tells the balancer that you are using 2 adhesive weights. Inner weight will be placed on the horizontal plane of the wheel at the outer edge of the inside of the wheel. The outer weight will be placed as far to the front as possible on the horizontal plane.

Static



This mode balances the wheel assembly using only a single weight plane. It does not compensate for side to side vibration as a dynamic balance would. Use only one adhesive weight located as close to center as possible on the inside horizontal plane. If desired a clip weight maybe used on the inner flange if 1.5 inches is added to 'D' (wheel diameter).

Alloy 2

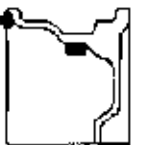

Same situation as stated in Alloy 1, but when a clip weight can be used on the inner rim flange. Tells the balancer that you are using clip weights for the inner rim flange, and adhesive weights for the outer weight. Outer weight will be placed as far to the front as possible on the horizontal plane.

Match Mount



This balancing procedure determines the optimum positioning of the tire on the rim so that a minimum amount of additional weight is required to balance the wheel. This procedure requires repositioning of the tire on the rim. After running the Match Mount procedure, select the desired balancing mode and balance the wheel. Use Match Mount when excessive radial runout is noticed in the tire and wheel during balancing, when the customer complains of ride problems, or when the balancer calls for weight in excess of 2 ounces on either plane of passenger car tires in the Dynamic mode.

Selecting Balancing Options

Hood Start

The balancer can be set to automatically start the spin cycle as soon as the hood is lowered completely and the hood safety interlock systems are engaged. Press and hold the SHIFT key and press 3. To return the balancer to normal mode, repeat the key sequence.

Round Off

The default weight measurement on the balancer is 0.25 ounces. The balancer can be set to a non-Round Off mode that displays weights in 0.01 ounce increments. Press and hold the SHIFT key and press 6 to toggle between the Round Off and non-Round Off modes.

Ounce/Gram

In the default mode, the balancer will operate in ounces. The balancer can be set to operate in grams by pressing and holding the SHIFT key and pressing 9. Toggle back to ounces by using the same key sequence. LEDs on the control panel indicate which weight measurement is currently selected.

Operator A/B

1050 Two operators can utilize the balancer without clearing or changing each others data. This is handy when one operator is running the Match Mount procedure and the other operator needs the balancer. If operator A is at a point in the Match Mount procedure where the wheel is removed from the balancer, operator B can access the machine by switching to the other operator memory. When B's balance is complete, he can toggle the machine back to A's memory. All of operator A's data is still present, and the Match Mount procedure can be continued without having to start over. Press and hold the SHIFT key and press 7 to toggle between the 2 operator memories. LEDs on the control panel indicate which operator memory is in use.

Clear

1025
1050
1055 This function clears the data in the currently selected operator memory only. The other memory is unaffected. Press and hold the SHIFT key and press 2 to clear.

Blank Rim

1025
1050
1055 This feature blanks out the wheel diameter measurement on the control panel display. The balancer continues to use the measurement even though the display is blank. This feature is typically utilized when the customer is within view of the balancer, and may become concerned by the measurement shown for the wheel diameter (typically when metric or odd size wheel diameters are displayed). Press and hold the SHIFT key and press 4 to blank the display. Repeat the key sequence to reactivate the display.

Reading the Displays

Weight Displays

The two weight displays (one for the inner plane, and one for the outer plane) are positioned with a wheel cross section diagram. After spinning the wheel, the balancer will calculate the weight needed and display it in these displays. The display to the left of the diagram will show the weight to be applied to the inner plane of the wheel and the display to the right will show the weight for the outer plane.

Error messages and system messages will also be shown in these displays.

Weight Position LEDs

Each weight display includes weight position LEDs. Located between the weight display and the diagram, these LEDs indicate the proper location for weight application. After a spin, rotate the wheel until the center position indicator LEDs flash. This indicates that the position specified by the balancer for weight application is at top-dead-center.

Display Messages

Both inner and outer displays will show 0.00 when the balancer is first turned on or after clearing the memory. The balancer may also display the following messages:

Err - An error was detected after the start button was pressed. The error is in one of the wheel measurements entered into the balancer. Check your measurements and re-enter as needed.

Err 3 - Circuit malfunction. Call the Hennessy Service Department at (800) 688-6359.

Hood (hod) - The hood has been raised during the balancing cycle. The balancer will automatically brake to a stop. The hood must be down with the safety interlock engaged for the balancer to spin.

Hub - The hub nut has come loose. The balancer will automatically brake to a stop when the wheel is 13 inches or larger in diameter. Retighten the hub nut and respin.

Balancing a Wheel

Procedure

The following steps walk through the balancing procedure. Do not proceed with these instructions until you have read and understand the previous sections of this guide (mounting, balance modes, and reading the displays).

1. Turn the balancer on. The power switch is on the rear of the unit, near the top and to the operator's left.

Note: When turned on, the balancer will activate the same options that were selected when it was last turned off (hood start, ounce/gram, etc.).

2. Mount the wheel to be balanced. Use the proper mounting method as described on pages 6 and 7. Always remove any weights attached to the wheel.

3. Enter the wheel measurements and select balancing mode.

4. Set options (hood start, ounce/gram, operator A/B).

5. Lower the hood and press START. The wheel will spin and then brake to a stop.

Note: Spin will start automatically when the hood is lowered if the hood start option is turned on.

6. Raise the hood.

7. Rotate the wheel until the outer position LEDs flash.

8. Attach the weight specified in the proper location at top-dead-center. Refer to the diagrams on the control panel for weight locations.

9. Rotate the wheel until the inner position LEDs flash.

10. Attach the weight specified in the proper location at top-dead-center. Refer to the diagrams on the control panel for weight locations.

11. Lower the hood and press START to respin the wheel. The wheel will brake to a stop. The weight displays should now read 0.00. If not, refer to page 11, Checking the Balance for assistance.

Remember: The more accurate you are in selecting and positioning the weight, the more often you will balance wheels with a single spin.

Changing Wheel Information During Balancing

The information entered into the balancer for A, W, and D can be changed at anytime during the balancing procedure. Follow the instructions provided earlier for entering the measurements manually. The balancer will recalculate weights and positions based on the new measurements.

Changing Balancing Modes During Balancing

The balancing mode can be changed at anytime and the balancer will recalculate weight and position based on the new selection. Does not apply when switching to and from Match Mount.

Checking the Balance

After applying the weights indicated by the balancer, respin the wheel. The displays should read 0.00.

If the balancer indicates an additional weight should be applied in the same location as the first weight, the first weight is too small. Correct the first weight and respin.

If the balancer indicates an additional weight should be applied directly opposite the first weight, the first weight is too big. Correct the first weight and respin.

If the balancer indicates an additional weight should be applied at an angle to the first weight, the first weight was not applied in the correct position. Move the first weight towards the position indicated for the second weight or add the second weight as indicated.

After Balance Vibration Problems

If vibration is still present after balancing the wheels and driving the vehicle on smooth pavement remove the wheels and recheck the balance. If a wheel is out of balance the cause may be:

1. A weight has come off the wheel. Remove the other weights from the wheel and rebalance.

2. Tire slippage on the wheel. Remove and remount the tire using proper tire lubricant and inflate to 40 PSI. Do not over-inflate. Rebalance the wheel and reduce air pressure to recommended PSI.

3. Stones or other foreign objects caught in the tire tread. Remove the objects and repair tire as necessary. Check and rebalance if needed.

If the balancer still indicates the wheels are balanced to within 0.05 ounces on both inner and outer displays, the problem is not in the balance of the wheels. Check the following possible sources of vibration:

1. Tire pressure. Bring all tires up to the recommended PSI.

2. Radial or lateral runout in the tire or wheel. Replace the damaged part.

3. Foreign material inside the tire. Remove the tire from the wheel, remove the material, and remount. Remove wheel weights and rebalance the wheel.

4. Imbalanced wheel covers or trim rings. Remove the wheel covers or trim rings and test drive. If the vibration is gone, remove the arbor and use the optional Combi-Adapter to mount the wheel to the balancer. Balance the wheel with the wheel cover or trim ring attached to the wheel.

5. Incorrectly mounted wheel. Remount correctly.

6. Damaged wheel bolt holes. Replace wheel.

7. Worn universal joints. Replace as required.

8. Drive shaft imbalanced or damaged. Balance, repair, or replace.

9. Imbalanced brake rotor(s) or drum(s).

10. Suspension out of alignment. Align the vehicle and replace any damaged or worn parts.

Match Mount

Description

The Match Mount program assists the user in determining the best possible mating of the tire and wheel, thereby reducing the amount of additional weight required for balancing. This mating of tire and wheel normally allows the least amount of total runout of the assembly, resulting in better balancing, better ride conditions, and more satisfied customers. Use Match Mount when:

- Excessive radial runout is noticed in the tire and wheel assembly during balancing.
- The customer complains of ride problems.
- The balancer calls for weights in excess of 2-ounces on either plane on passenger car tires in the Dynamic mode.

Match Mount balancing requires loosening both tire beads and inflation of the tire. You will need to be trained in the operation of your Coats tire changer and the dangers involved during bead seating and tire inflation. Read the operator's manual supplied with the tire changer and consult your supervisor.

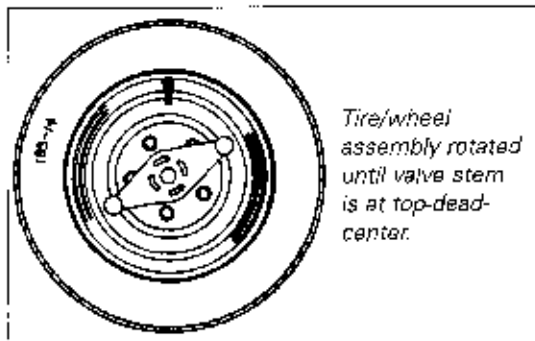

Figure 17 - Rotate the wheel

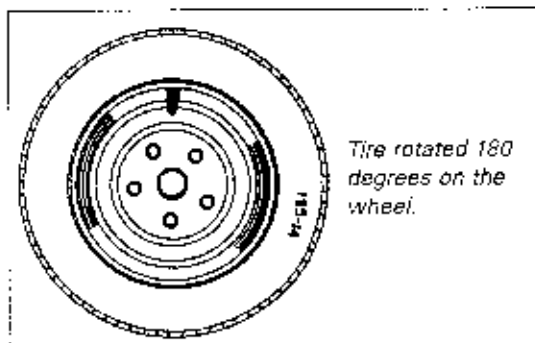

Figure 18 - Rotate Tire on Wheel

1025 The balancer will be idle while the tire is being rotated on the wheel. During these times, another operator without terminating the Match Mount procedure can use the balancer. The second operator selects the other operator memory, performs a balance, and then returns the balancer to the previous memory. The original operator can now continue the Match Mount procedure.

As with any balancing procedure, remove any weights attached to the wheel and inspect the tire and wheel before beginning.

Instructions

1. Mount the wheel to the balancer.
2. Select the appropriate operator memory as required. Make a note of the memory being used in the event the memory is changed during the Match Mount procedure.
3. Enter the A, W, and D measurements and select the mode that will be used for the final balancing.
4. Lower the hood and press START.
5. Wait for the wheel to brake to a stop and for the displays to show weight readings.

Does the balancer indicate that 2-ounces or more is required on either plane of the wheel in dynamic mode? Higher weights may be indicated when using an alloy mode to compensate for weight location.

If so, advise supervisor or customer to continue with the Match Mount procedure. DO NOT attach weights at this point.

If not, the Match Mount procedure is most likely not necessary, and will not improve the balance. Continue to balance the wheel according to the mode selected.

6. If hood start option is on, turn it off now.
 7. Press the MODE key until Match Mount is selected.
 8. 1 will now be displayed in the outer weight display.
 9. Raise the hood and rotate the wheel until the valve stem is at top-dead-center.
 10. Press (1) on the control panel. 2 is now displayed in the weight display.
 11. Remove the wheel from the balancer. Completely deflate the tire by removing the valve core. After all the air pressure is exhausted, follow the tire changer manufacturer's instruction for loosening the tire beads.
- 1025** A second operator can use the balancer while the Match Mount operator does Steps 12, 13, and 14. **Remember:** All data for the Match Mount procedure will be kept in the Match Mount operator's memory.
12. Lubricate both tire beads and wheel to aid in rotating the tire and bead seating and seating. Always use the tire manufacturer's approved rubber lubricant.
 13. Rotate the tire 180° on the wheel.

14. Replace the valve core and inflate the tire. Follow the tire changer manufacturer's instructions for inflation.

1025 **Remember:** if another operator memory has been selected, reselect the memory being used for the Match Mount procedure. The balancer will return to the point in the procedure where the other memory was selected.

15. Remount the wheel on the balancer.

16. Press [2] on the control panel. 3 is now displayed in the weight display.

17. Lower the hood and press START.

18. Wait for the wheel to stop. Raise the hood and rotate the wheel until the valve stem is at top dead center.

19. Press 4 on the control panel.

Weights will now be displayed on the control panel. The weight in the left display is the weight imbalance for the rim (as indicated by the RIM light below the display). The weight in the right display is the weight imbalance for the tire (as indicated by the TIRE light below the display).

Use these weights to determine the suitability of the rim or tire. High imbalance may indicate a rim that is cut-of-round or misformed, or a tire with a bubble or other problem. If the imbalance is excessive, it may be prudent to replace the rim, the tire, or both. If either is replaced do not continue this procedure. Balance the new tire and rim and evaluate the readings for Match Mount suitability.

20. Rotate the wheel until the weight position LEDs flash. Mark the tire at top-dead-center.

21. Remove the wheel from the balancer. Completely deflate the tire by removing the valve core. After all the air pressure is exhausted, follow the tire changer manufacturer's instruction for loosening the tire beads.

1025 A second operator can use the balancer while the Match Mount operator continues with Steps 22, 23, and 24.

1050

1055 **Remember:** All data for the Match Mount procedure will be kept in the Match Mount operator's memory.

22. Lubricate both tire beads and wheel to aid in rotating the tire and bead sealing and seating. Always use the tire manufacturer's approved rubber lubricant.

23. Rotate the tire until the mark is aligned with the valve stem.

24. Replace the valve core and inflate the tire. Follow the tire changer manufacturer's instructions for inflation.

1025 **Remember:** If another operator memory has been selected, return the balancer to the memory being used for this Match Mount procedure. The balancer will return to the exact point in the procedure where the other memory was selected.

25. Remount the wheel on the balancer.

26. Use the MODE key to select the desired balance mode and balance the wheel.

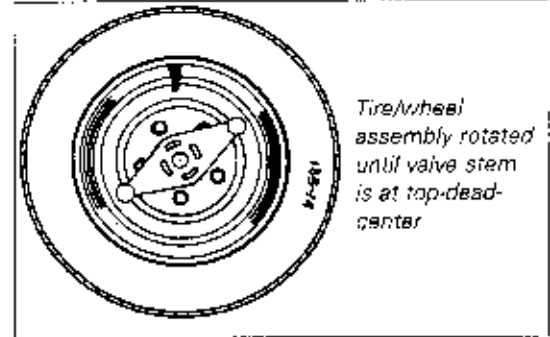

Figure 19 - Rotate the Wheel

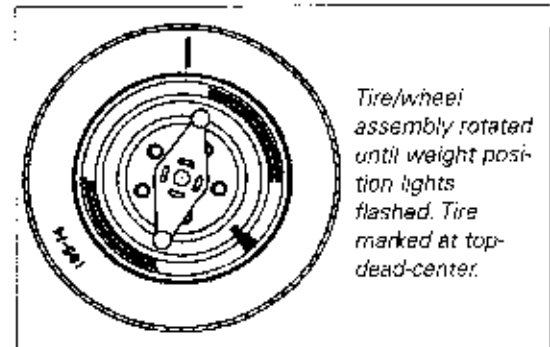

Figure 20 - Rotate the wheel

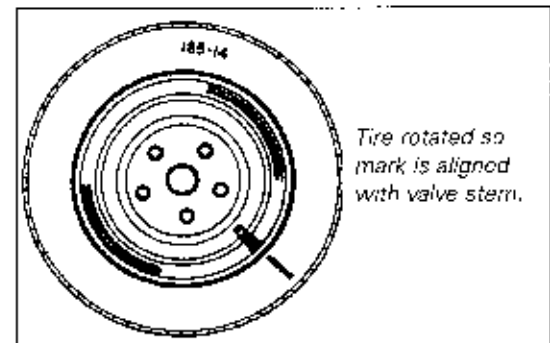

Figure 21 - Rotate Tire on Wheel

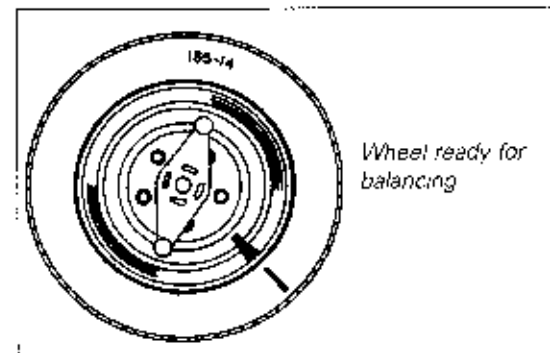

Figure 22 - Match Mount Completed

Maintenance and Calibration

Preventative Maintenance

The balancer requires only minor maintenance to keep the unit operating properly.

1. Keep the display clean and clear. Use a vaporizing cleaner only. Do not use cleaners or solvents, which leave oily or filmy residues behind.
2. Keep the adapters, cones, faceplate, threaded arbor, pressure cup, and hub nut clean. Grease and dirt buildup will cause premature wear and inaccurate balancing. Clean at least once a day with a vaporizing solvent.
3. Clean the weight tray, accessory post, and pegs. Weights stored in a dirty tray will pick up grease and dirt which may alter their weight or keep them from securely attaching to the wheel. Use a vaporizing solvent to clean the tray, pegs, and post.
4. Keep the area around the balancer clear. Remove any tools or other items that are leaning against the balancer. Keep the area under the balancer clear as well. Remove any items that may cause the balancer to not sit level.
5. Use only COATS accessories. Accessories from other manufacturers may not fit or function properly, and may damage the balancer.

Calibration

The balancer utilizes a 'self calibration' scheme. To keep your balancer in proper calibration, this calibration procedure should be performed once a month, or whenever the accuracy of the balancer is questioned.

1. Mount a 14, 15, or 16-inch diameter x 6 - 6 1/2-inch wide steel wheel assembly on the balancer. It should be suitable for mounting using the back cone method and have a properly inflated tire.

2. Enter A, W, and D wheel measurements.

Note: The A entry must be between 5.0 and 8.0, and W entry must be between 5.5 and 7.0. If the wheel you have mounted does not meet these requirements, select a different wheel and try again.

3. Remove any weights attached to the wheel.

4. Press and hold SHIFT and press 1.

5. Lower the hood and press START.

6. Raise the hood, rotate the wheel until the outer weight positioning LED flashes, and attach a 4-ounce calibration weight if in ounce mode or a 100-gram calibration weight if in gram mode at top-dead-center.

Note: It is critical that this weight be placed accurately to achieve proper calibration.

7. Lower the hood and press START.

8. Raise the hood and remove the weight.

The balancer is now calibrated. If a mistake is made during this procedure, turn the balancer off, then back on, and start the procedure over again.

1025
1050
1055

Distance Gauge Calibration

1. Securely mount your calibration wheel.
2. Press and hold SHIFT and press 0. The display will read CDE to indicate it is ready for a code.
3. Press 1 then 0. The inner weight display will now read 0.08 to 0.22 and the outer weight display will read 0.55 to 0.70.
4. Rotate the distance gauge to its maximum rotation (towards the front of the balancer) and hold it there.
5. Press MODE.
6. Release the distance gauge and allow it to return to its stored position.
7. Press MODE.
8. Pull the distance gauge out and rotate it until it touches the inner edge of the rim flange. Hold it there.
9. Press the wheel offset key (A) and enter the distance measurement shown on the gauge.
10. Press the wheel diameter key (D) and enter the diameter of the wheel as shown on the tire sidewall (for example, enter 140 for a 14-inch wheel).

The inner and outer display will now change to zeros.

11. Release the distance gauge and let it return to its stored position.

The distance gauge is now calibrated. However, the wheel measurements displayed may vary by ± 0.3 inches depending upon the condition of the rim.